

# Knowledge-based approach for the integration of the Planning and Scheduling decision-making levels

Miguel Zamarripa<sup>a</sup>, Mariana Cocco<sup>b</sup>, Kefah Hjaila<sup>a</sup>, Javier Silvente<sup>a</sup>, Carlos Méndez<sup>b</sup>, Antonio Espuña<sup>a,\*</sup>

<sup>a</sup>Universitat Politècnica de Catalunya. ETSEIB, Chemical Engineering Department. 647 Diagonal Avenue, 08028 Barcelona (Spain)

<sup>b</sup>INTEC (Universidad Nacional del Litoral-CONICET), Güemes 3450, Santa Fe (Argentina)  
antonio.espuna@upc.edu

This work aims to integrate the tactical and operational decision making levels. A typical Scheduling mixed integer linear programming (MILP) model has been solved using several demand scenarios. The results have been analyzed and accordingly the operation cost vs. production levels nonlinear equations have been obtained. The aforementioned equations have been included as constraints of the SC planning problem. Hence, production, inventory and distribution variables along the complete SC have been optimized using a NLP model.

## 1. Introduction

The problem of decision making associated to Supply Chain (SC) tactical management (procurement of raw materials in different markets, allocation of products to different plants and distributing them to different customers) has been studied during the last two decades. But nowadays, chemical industry faces new challenges which increase the pressure for an improved decision making, able to better exploit plant and process flexibility. The case of batch processes, because of its inherent flexibility, offers a significant improvement potential in this line.

An increasing number of works have been published in the academic literature addressing decision making problems dealing with the coordination of inventory, production and/or distribution tasks. A significant number of these works addresses the problem of SC production planning for multi-product or more complex production networks including production-distribution options. Many researchers considered MILP models for their optimization including uncertainty management (Gupta and Maranas, 2000), nonlinear models (Neiro and Pinto, 2004), and environmental issues (Hugo and Pistikopoulos, 2005). But it is not easy to find works in the literature addressing the three main tasks involved in optimizing SC planning problems (inventory, production and distribution tasks) specially for the case of more general operation networks including, for example, multipurpose pathways, combination of different intermediate storage policies, task changeovers management, etc. (McDonald and Karimi, 1997).

In the operational decision making level, Kondili et al. (1993) presented the state-task network representation for batch processes allowing handling many complexities in this kind of processes. Departing from this representation, several models, based on discrete and continuous time representations, were formulated in order to solve short-term scheduling problem (Maravelias and Grossmann, 2003). It is worth mentioning that in most of these approaches, the optimization is based on information derived from previous decision making models, typically, associated to the strategic and tactical decision making levels.

The nature of both planning and scheduling deterministic problems hinders their joint resolution, principally, due to the computational effort needed to solve the explicitly planning-scheduling model resulted from the time horizon considered by each decision level.

The integration of several/different hierarchical levels has been studied in Process System Engineering (PSE) literature. In this line, for example, Laínez et al. (2007) integrated SC design-planning model and financial issues to improve the decision making in chemical processes, or Floudas and Lin (2004) presented an integrated design, synthesis and scheduling approach under uncertainty to avoid unfeasible operation conditions for the required plans. In this line, Giarola et al. 2011 developed a MILP model for integrated design-planning decision making of bio-ethanol supply chains where multiple objectives have been considered. Applications in production planning and integrated scheduling have been also covered in several works; for example, Guillén et al. (2006) presented an integrated planning/scheduling two stage model of multi-product and multi-echelon distribution networks, which takes into account financial management issues, and solved it using a rolling horizon approach. Sung and Maravelias (2007) also developed a hybrid planning-scheduling optimization technique, where optimal schedules were obtained in

an off-line optimization; then, these results were integrated into the planning model as linear approximations constraining the production capacities of the SC network considered. In this line, Wilkinson et al. (1996) presented a detailed production-distribution scheduling model, where, a multipurpose production plant for the European market case study has been presented (widely used in literature), or Jackson and Grossmann (2003) presented a temporal decomposition scheme for an integrated production-distribution model.

### 1.1 Main Objectives

In this paper, the integration of the tactical and operational decision making at the SC level is also intended. The recursive resolution of the operational decision making problem under several demand scenarios has been considered and thus, a generic (non linear) relationship between the production level and the production cost can be obtained. This behaviour is then included in a general production planning model in order to improve the decision making.

## 2. Problem Statement

### 2.1 Supply Chain Planning

The scope of the SC planning problem is typically to determine the optimal production levels, inventories, and product distribution in an organized network of production sites, distribution centres', consumers, etc. taking into account the constraints associated to products and raw materials availability, storage limits, etc. in the network nodes. Planning tasks involve in selecting the best possible SC network operation (production plants, storage centres, and distribution tasks) to meet the customer's satisfaction.

Production planning overestimates the SC network and intends to maximize the efficiency of the material flows to satisfy the market considering weekly; monthly; or annual resolution of the proposed model and disregarding the issues associated with the process operation, goods and product transportation, and unexpected situations during the plan resolution. Also, constant process duration, production and product costs are considered through linear functions to represent the process behaviour.

### 2.2 Scheduling

The operational decision making level (Scheduling) aims at allocating the resources of the production plant (tasks and units). The problem and the subsequent formulation presented in this paper are based on a state-task network (STN) representation (Kondili et al., 1993) of the different involved processes. In this work, short term scheduling using discrete time representation has been considered. Typical scheduling models consider several constraints, such as: equipment allocation, storage levels, availability of raw materials, and batch size and production deliveries in order to satisfy customer demands at the minimum total cost. The resulted scheduling problem is formulated as an MILP over the time horizon (hours or weeks). Commonly, temporal needs are not explicitly included (i.e. charge and discharge, clean times, etc.) into the mathematical model.

### 2.3 Mathematical model

The short term scheduling model used in this work is based on the work of Kondili (1993). From this model, several additional elements have been introduced and/or modified, as follows:

First, Eq. 1 has been included in order to force the problem to achieve the forecasted demand ( $D_{s,p,t}$ ) for each product p at the end of the time period t.

$$S_{s,t} \geq D_{s,p,t} \quad \forall s \in \{FP\}, t = TF \quad (1)$$

Where:  $S_{s,t}$  represents the quantity of material s at time t. In this case: the quantity of s (final products FP) must satisfy the demand at the end of the time horizon TF.

Hence, the minimization of the total cost has been formulated as the objective function of the scheduling problem considering the cost to use the equipments, the storage cost and the production level cost.

$$z = \sum_t^I \sum_j^J \sum_t^T W_{i,j,t} * fcost + \sum_t^{TF} \sum_s^S S_{s,t} * Scost + \sum_t^I \sum_j^J \sum_t^T B_{i,j,t} * Vcost \quad (2)$$

Where:  $fcost$  represents the fixed cost  $fcost=f+(a)^t$ ,  $Scost$  represents the storage cost penalizing the storage over the time  $Scost = s+(b)^t$ ;  $Vcost$  represents the variable cost also penalized over the time horizon  $Vcost= v+(c)^t$ .

Using this approach, several demand scenarios have been optimized for all the products, and a mathematical model has been fitted to the obtained results.

A general production planning model relating the “possible” production and costs as function of the process operation has been developed by Sung and Maravelias (2007). The model also considers inventory, backorder tasks and costs, material balances and demand satisfaction. The resulting nonlinear equations obtained by the data of the scheduling problem must be introduced in Eq. (3) and Eq. (4) of the general planning problem.

$$F(P_{kt}) \leq 0 \quad \forall t \quad (3)$$

$$Cp_t = C(P_{kt}) \quad \forall t \quad (4)$$

The production planning problem is then optimized towards minimizing the total cost (objective function, Eq. 5). The total cost is obtained by summarizing the production cost ( $Cp_t$ ), holding cost ( $Ch_t$ ) and the backlog cost ( $Cu_t$ ).

$$CT = \sum_{t=1}^T Cp_t + Ch_t + Cu_t \quad (5)$$

Finally, the resulting SC planning NLP model has been solved through General Algebraic Modelling System (GAMS, using CNOPT + CPLEX) as the solver.

### 3. Case study

#### 3.1 Description

The case study has been divided into two parts: Part I (scheduling problem) is based on the scheduling example proposed by Kondili et al. (1993), which, has been widely used in the scheduling literature (see, Figure 1). The problem to be solved involves 5 tasks (heat, reaction 1, reaction 2, reaction 3 and distillation); 9 states (feed A, feed B, feed C, hot A, intermediate AB, intermediate BC, impure C, product 1 and product 2); and 4 equipment units (1 heater, 2 reactors and 1 distiller). Parameters of the objective function are: fixed cost ( $f=2$  €/kg,  $a=0.715$ ), holding cost ( $s=1$  €/kg,  $b=0.715$ ), and Variable cost ( $v=1$  €/kg,  $c=0.715$ )

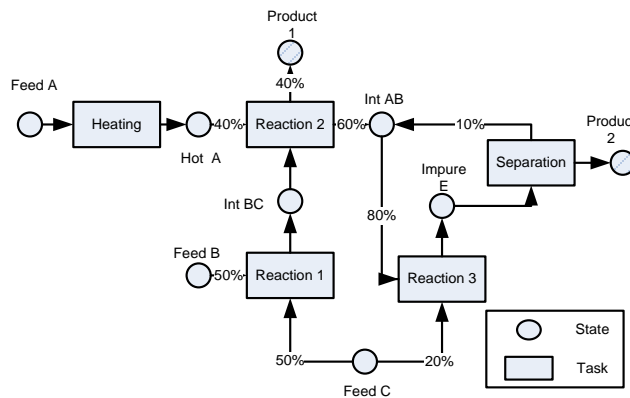

Figure 1: STN case study.

Part II (planning problem) considers one production plant that must satisfy a forecasted demand of two products distributed to one market (Mk1). Production, backlog, and inventory management must be optimized over the considered time horizon (six months). Fixed holding ( $P1: 10$ ;  $P2: 20$ ) and backlog ( $P1: 2$ ;  $P2: 3$ ) costs have been considered for each product.

#### 3.2 Results

The optimal assignment of equipment units to tasks and the resulting schedules were determined in order to satisfy the proposed goals in several demand scenarios (Figure 2). For each demand scenario, the optimal scheduling has been obtained. The results show the best equation to be used in order to represent the performance of each product (Table 1).

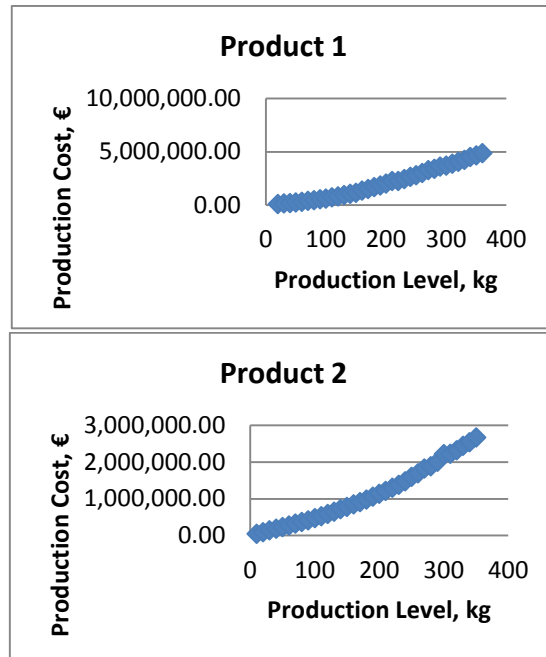

Figure 2: Production cost vs. product demand (Scheduling model)

Table 1: Data analysis

Product	Equation	R <sup>2</sup>	Parameters	
Product 1	$Y=A \cdot X^B$	0.9984	A: $0.4736 \cdot 10^3$	B: $0.1571 \cdot 10^1$
Product 2	$Y=A \cdot X^2+B$	0.9841	A: $0.2091 \cdot 10^2$	B: $0.2387 \cdot 10^6$

The aforementioned equations have been introduced in the planning problem. The optimal production, storage and distribution decisions have been obtained. Figure 3 shows the production and inventory levels for all the time periods. In this case study, the holding cost represents minimum part of the total cost: the production-distribution policy dominates the decision making during the time horizon. Nevertheless, the inventory is used to save production penalties while distribution costs have been disregarded due to the number of markets.

Figure 4 corresponds to the economic analysis; as can be observed; production cost represents the highest cost in a SC (then, further improvements in the production tasks will impact directly in the SC performance).

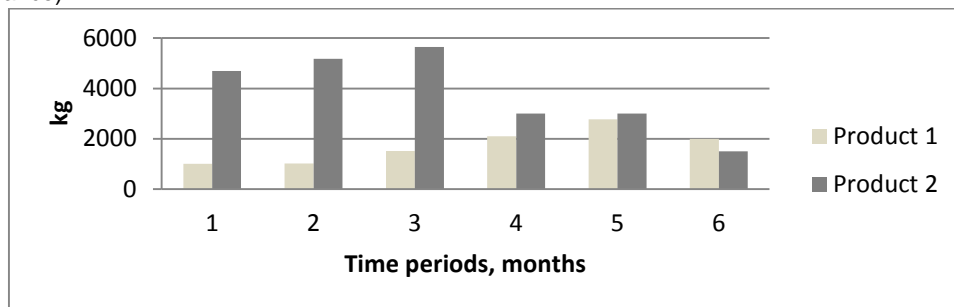

3a Production levels

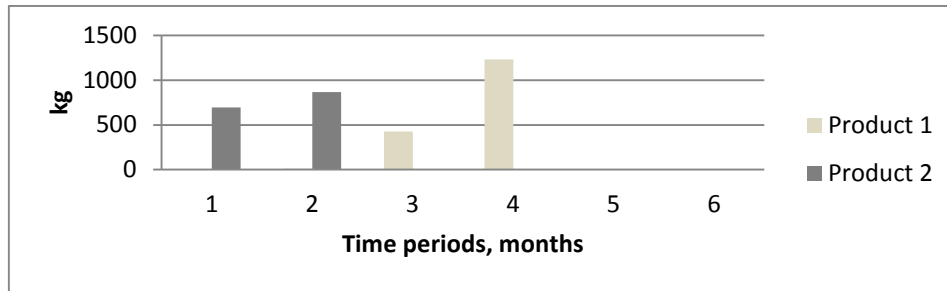

3b Inventory Levels

Figure 3: Production and inventory levels.

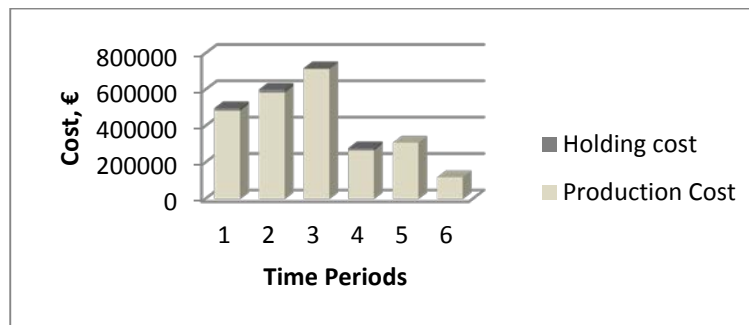

Figure 4: Economic analysis

Finally, the sales and total cost at each time period have been computed. As a concluding remark for this case study, an important increment of the demand will allow us to observe more holding and/or backorder actions since the plant is at its maximum capacity. Table 2 illustrates the total costs and sales during all time periods (P1=product 1; P2: product 2; PC: Production Cost; HC: Holding Cost).

Table2: Economics

€	t1	T2	t3	t4	t5	t6	Total
PC (P1)	24,459	24,992	47,017	78,577	121,110	72,671	
PC (P2)	461,176	559,861	668,110	188,428	188,428	47,286	
HC (P1)	-	138	4296	12,316	-	-	
HC (P2)	13901	17368	-	-	-	-	
Total Cost	499,536	602,359	719,423	279,321	309,538	119,957	2,530,136
Sales	626,460	680,585	788,416	561,217	634,520	385,000	3,676,200
						Benefit	1,146,063

Even if the production planning case study represents a small production network, the model considers the complexity associated to the tactical management (production, distribution, storage and backlog variables to be optimized).

#### 4. Conclusions

This work contributes to the improvement of decision making process. A novel NLP model has been developed integrating operational knowledge and tactical management to optimize typical SC planning problems. This is an important improvement in the process optimization in terms of flexibility and integration in the decision making process.

The production network has been used in order to prove the proposed approach. Successful integration of decision making levels, analysis, and optimization tools have been obtained. The proposed approach can be extended to wider case studies.

Some opportunities remain open in this kind of works. In the case study presented (production cost vs. production level), the products have been considered as independent variables. In order to improve the results, the products analysis could be considered as dependent variables. The complexity of the

scheduling problem might require the use of more complex models to ensure that all the basic information is retained by the surrogate model. The introduction of other nonlinearities in the model (i.e.: in the cost functions) and the existence of process alternatives, leading to integer constraints, will affect the mathematical behaviour of the resulting model, which may require alternative formulations and/or the use of other mathematical programming tools. And the case of integrating a large number of echelons in the SC will exponentially increase the size of the problem. Finally, uncertainty should be also considered to reach more robust solutions to the decision-making problem.

### Acknowledgements

The authors would like to thank the financial support received from: the Mexican “Consejo Nacional de Ciencia y Tecnología (CONACYT)”, the Spanish “Ministerio de Economía y Competitividad”, the European Regional Development Fund (Projects EHMAN, DPI2009-09386 and SIGERA, DPI2012-37154-C02-01), the Subprograma de Formación de Personal Investigador, BES-2010-036099, and the “Agencia Española de Cooperación Internacional para el Desarrollo” (Acción AECID PCI2011 A1/044876/11).

### References

- Floudas C. A., Lin X., 2004, Continuous-time versus discrete-time approaches for scheduling of chemical processes: a review, *Computers and Chemical Engineering*, 28, 2109-2129, DOI: 10.1016/j.compchemeng.2004.05.002
- Guillén G., Badell M., Espuña A., Puigjaner L., 2006, Simultaneous optimization of process operations and financial decisions to enhance the integrated planning/scheduling of Chemical supply chains, *Computers and Chemical Engineering*, 30, 421-436, DOI: 10.1016/j.compchemeng.2005.10.015
- Gupta A., Maranas C.D., 2000, A two-stage modelling and solution framework for multisite midterm planning under demand uncertainty, *Industrial Engineering Chemistry Research*, 39, 3799-3813, DOI: 10.1021/ie9909284
- Giarola S., Zamboni A., Bezzo F., 2011, Supply Chain Design and Capacity Planning: from First to Second Generation Biofuel Systems, *Chemical Engineering Transactions*, 24, 253-258, DOI: 10.3303/CET1124043
- Hugo A., Pistikopoulos E.N., 2005, Environmentally conscious long-range planning and design of Supply Chain networks, *Journal of Cleaner Production*, 12, 1471-1491, DOI: 10.1016/j.jclepro.2005.04.011
- Jackson J.R., Grossmann I.E., 2003, Temporal Decomposition Scheme for Nonlinear Multisite Production Planning & Distribution Models, *Industrial Engineering Chemistry Research*, 42, 3045, DOI: 10.1021/ie030070p
- Kondili E., Pantelides C.C., Sargent R.W.H., 1993, A general algorithm for short-term scheduling of batch operations – I. MILP formulation, *Computers and Chemical Engineering*, 17, 211–227, DOI: 10.1016/0098-1354(93)80015-F
- Laínez J. M., Guillén G., Badell M., Espuña A., Puigjaner L., 2007, Enhancing Corporate Value in the Optimal Design of Chemical Supply Chains, *Industrial Engineering Chemistry Research*, 46, 7739-7757, DOI: 10.1021/ie070181e
- Maravelias C.T., Grossmann I.E., 2003, New General Continuous-Time State-Task Network Formulation for Short-Term Scheduling of Multipurpose Batch Plants, *Industrial Engineering Chemistry Research*, 42, 3056-3074, DOI: 10.1021/ie991098x
- McDonald C.M., Karimi I.A., 1997, Planning and scheduling of parallel semi continuous processes. I. Production planning, *Industrial Engineering Chemistry Research*, 36, 2691–2700, DOI: 10.1021/ie960901+
- Neiro M.S., Pinto J.M., 2004, A general modelling framework for the operational planning of petroleum Supply Chains, *Computers & Chemical Engineering*, 28, 871-896, DOI: 10.1016/j.compchemeng.2003.09.018
- Sung C., Maravelias C.T., 2007, An attainable region approach for production planning of multi-product processes, *AIChE Journal*, 53, 1298-1315, DOI: 10.1002/aic.11167
- Wilkinson S.J., Cortier A., Shah N., Pantelides C.C., 1996, Integrated production and distribution scheduling on a Europe-wide basis, *Computers & Chemical Engineering*, S20, S1275–S1280, WOS:A1996UR31000085